

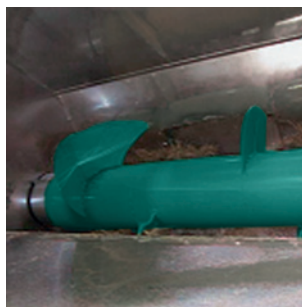

GEA Farm Technologies

Mix Feeder

Intelligent feeding
that cows just love to lap up!



GEA Farm Equipment | [Mullerup](#)

GEA Farm Technologies – The right choice.

Sit back and take things easy during feeding!

In the future let a good part of your work be made easy: The Mix Feeder is the fully automated feeder that you can entrust with individual mixing and distribution in your free stall barn around the clock. The Mix Feeder carries out its tasks in such a relaxed, precise and quiet manner that you can just sit back and watch.

Mixtures for a sense of happiness

Whether it is for top-performing cows, heifers, dry cows – the Mix Feeder will make the optimal TMR ration. Depending on the computer control command the Mix Feeder travels to the silage bunkers and weighs in feed ingredients according to the feed plan for each animal group. After the mixing follows distribution for the pre-programmed feeding groups. It is so easy to get your cows to perform because of the fresh mixed silage.

The cows just lap it up!

The cows are happy with the Mix Feeder. The low noise of its weighing, mixing and distribution ensures a relaxed atmosphere in the cow barn, avoiding stress and rush. You can despatch the feeder when and as often as you want! A frequent cycle frees you and your staff from time-consuming routine work, ensures calm during the distribution of the feed and avoids over-feeding of the cows.

A thoroughly clean yield right up to the final milk

Cows like things to be so clean that they can eat from the floor. Therefore the rail-mounted Mix Feeder carries out the feeding freely suspended directly above the feed-alley. Dirt from vehicle tyres, contaminating the feed, is

thus a thing of the past. That means clean feed for a thoroughly clean milk yield.

Always fresh onto the feed alley

Reduce your share of the work down to the filling up of the silage bunkers! The storage of silage in separate bunkers prevents things such as fermentation processes and the continuous preparation of fresh mixed feed rations ensures top quality silage on the feed alley. Thus you can be sure at the same time that important nutrients reach your cows around the clock!

Mix Feeder – the system with taste

- battery-driven, rail-mounted and computer-controlled feeder
- 4 energy-efficient models, depending on application and cow numbers size: PLUS, XL, AC, AC XL
- space-saving integration or upgrading, suitable for free stall barns with feeding tables of > 2 metres
- clean, fresh feed; healthy, high-yield cows
- effective, all-round solution for forward-looking production holdings
- intelligent and time-saving system from your partner GEA Farm Technologies

Workload: a minimum of effort is needed for the filling up of the bunkers

Reliable, as often as you want: Simply program and sit back – the Mix Feeder mixes and feeds to your requirements!



Flow chart

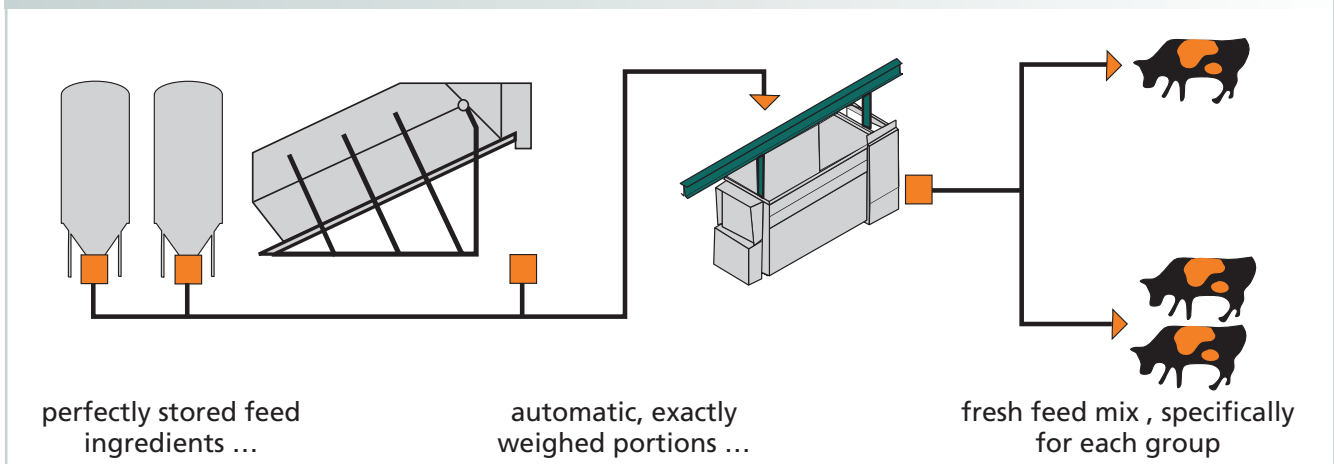

Technical specifications

Mixes per day	Individual - typically 20-30 loads			
No. feeding groups	Max. 15			
No. feed types	Max. 9 per group			
Mixing time	Adjustable - typically 4-6 min.			
Forward speed	16 m/min.			
Control	IF2 Controller/PDA			
External power	9,2 kW gear motor			
	Mix Feeder Plus	Mix Feeder XL	Mix Feeder AC	Mix Feeder AC XL
Batteries	4 x 12 V 100Ah	6 x 12 V 100Ah	4 x 12 V 100Ah	6 x 12 V 100Ah
Battery charging place	2 x 10 Amp. 24 VDC	4 x 10 Amp. 24 VDC	4 x 15 Amp. 12 VDC	6 x 15 Amp. 12VDC



Menus for each group for a sense of happiness: fresh feed in all parts of the clean feed alley

GEA Farm Technologies

The right choice.



GEA Farm Technologies GmbH

Siemensstraße 25 - 27, D-59199 Bönen
Tel. +49 (0) 23 83 93 7-0, Fax +49 (0) 23 83 93 8-0
www.gea-farmtechnologies.com