

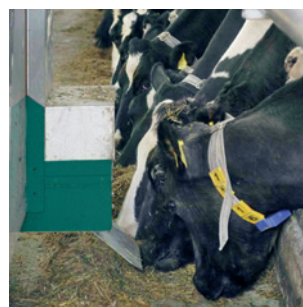

GEA Farm Technologies

## Free Stall Feeder

An optimised feed supply system  
leads to high-quality milk

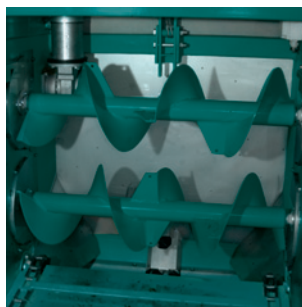
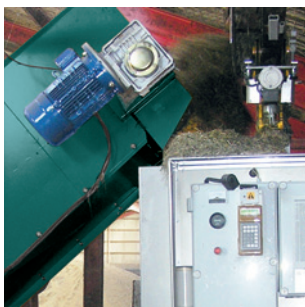

GEA Farm Equipment | Mullerup

GEA Farm Technologies – The right choice.

# Ready for automatic feeding, open to new ideas

The optimization of animal feed, increased yield, long-term growth or expansion of the herd – whatever thoughts come into mind when thinking about the subject of TMR feeding – the Free Stall Feeder transfers your ideas directly onto the feed alley.

The rail-mounted feeder provides your herd with a finely measured amount of feed from a stationary mixer or a silage bunker – reliably and round the clock. This results in a terrific saving in time and labour for you every day. The system is space saving, thus reducing the costs for any extension to your cow barn and is similarly suitable for any upgrading. Give a free rein to your plans for the future, the Free Stall Feeder will support you on the path to top-quality milk!

## Set up an independent feed supply system in your free stall barn

The Free Stall Feeder weighs-in TMR from a stationary mixer and each group will then have exactly the numbers of kilo which you want! Quietly and with amazing precision it then distributes its contents onto the feed alley in a programmed cycle - thanks to its feed conveyor either on left- or right side. Which group receives its TMR ration, at what time, how much and how often, is determined through computer control by you alone!

## As thanks the cows clear up the table

Take advantage of the benefits of the Free Stall Feeder and the feeding system using TMR strategies: The volume of TMR can be divided among the animal groups and adjusted depending on the current performance, while selective feed intake can be avoided. Multiple dispensing activates the cows resulting in a relaxed atmosphere as well as minimizes feed loss and prevents over-feeding. Healthy animals will make the automatic feeding system worthwhile by rewarding you with litre upon litre of top-quality milk!

## It is your choice: the correct volume to match the size of your herd

The Free Stall Feeder is available in three sizes. You can select from the models M1600, M2000 and M3000 a volume which provides the ideal basis for your farm, your herd and your personal plans.

## Free Stall Feeder - the advantages at a glance

- feeding for each animal group, based on their needs
- improved feed intake and utilization through frequent feeding
- a minimum of effort required to fill the stationary mixer or silage bunker
- little space required, the width of feed-alley can be reduced to 2 metres
- safe, proven system with the whole of the experience of your partner GEA Farm Technologies



*A minimum of work to fill the stationary mixer (example here: a 22 m<sup>3</sup> stationary mixer MVM22).*



*Busy supplier of feed: The computer-controlled, battery operated feeder serves up the feed for each animal group.*

## Flow chart

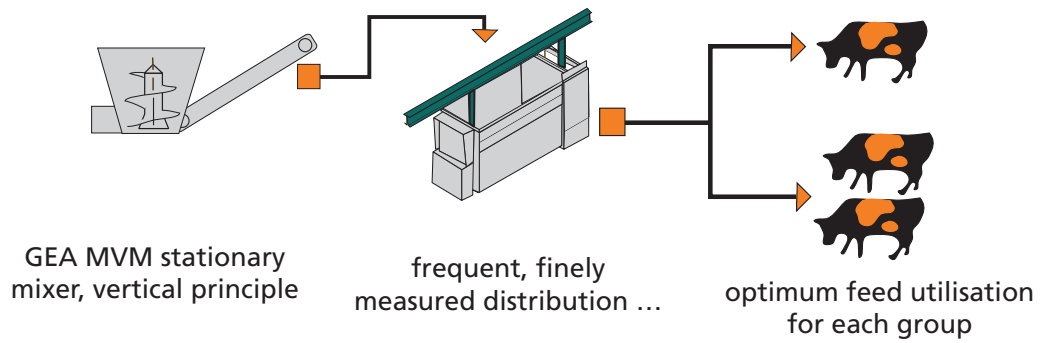

## Schematic diagram

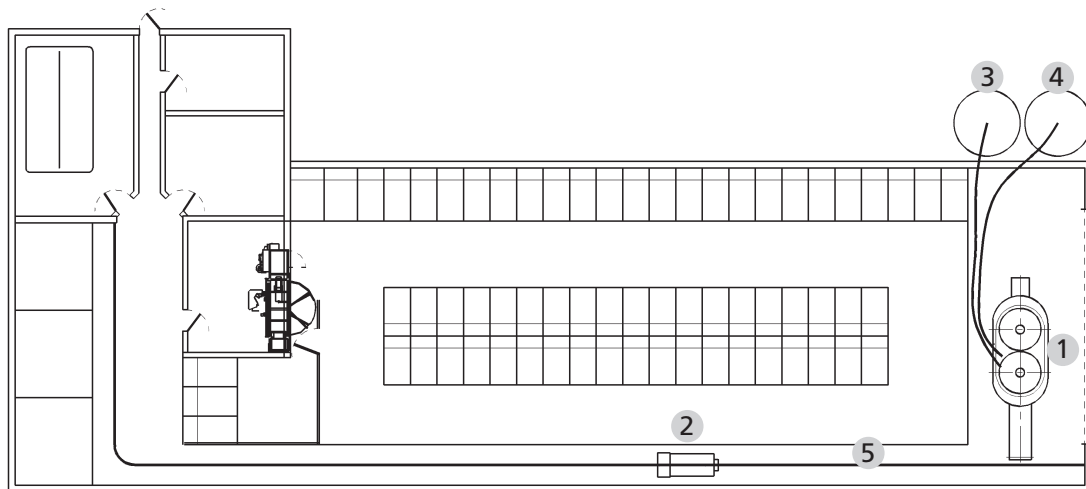

- 1 Stationary MVM mixer
- 2 Mullerup Free Stall Feeder
- 3 Concentrates from silage hopper 1
- 4 Concentrates from silage hopper 2
- 5 Rail

## Technical specifications

Mixes per day	Typically 25 loads
No. feeding groups	Max. 15
No. feed types	3
Total weight	Max. 2.500 kg
Speed	16 m/min.
Control	IF2 Controller/PDA
Batteries	4 or 6 x 12 V 100 Ah gel batteries

# GEA Farm Technologies

## The right choice.



GEA Farm Technologies GmbH

Siemensstraße 25 - 27, D-59199 Bönen  
Tel. +49 (0) 23 83 93 7-0, Fax +49 (0) 23 83 93 8-0  
[www.gea-farmtechnologies.com](http://www.gea-farmtechnologies.com)